



**AST 550** (Version: AMOSAST550OP20130402)

# **Fully-automatic Cryostat Microtome**

## **Operation Manual**

AMOS SCIENTIFIC PTY.LTD. ABN37 159 778 140

[www.amos-scientific.com](http://www.amos-scientific.com)

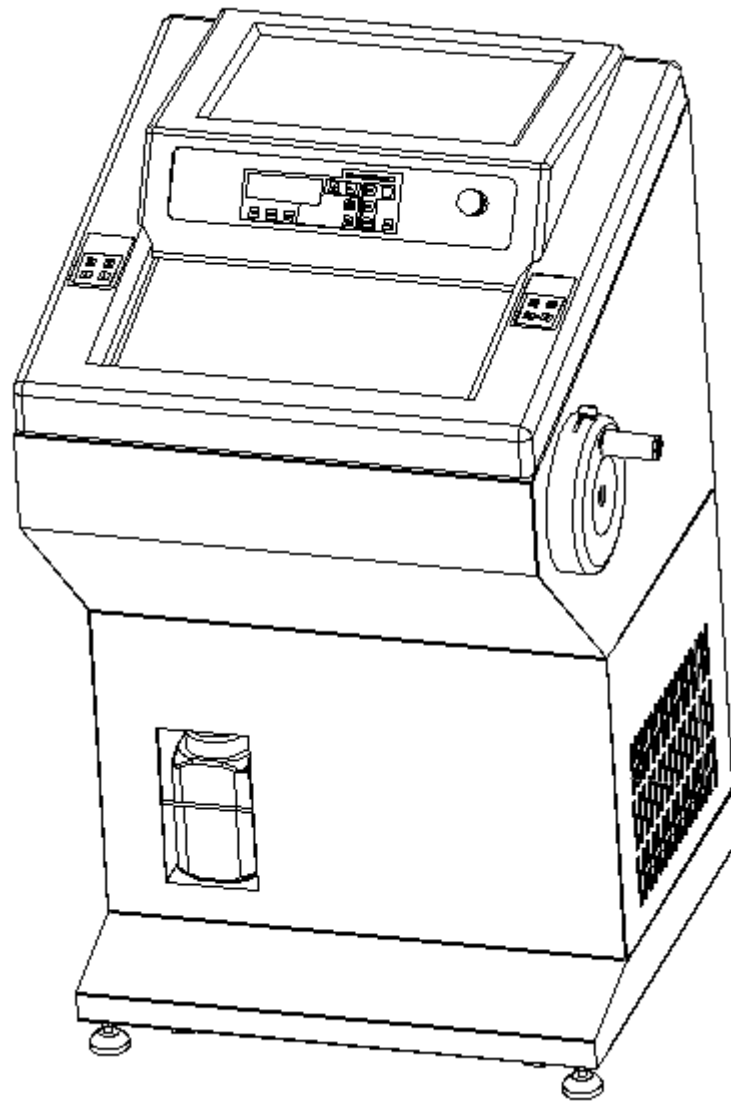

Presented in this Operation manual are the structure , functions and using notice . Reading carefully prior to operating the instrument .

# Foreword

AST550 Cryostat Microtome is a fully-automatic microtome whose design concept comes from customers all over the world , it can meet different requirements for tissue section .

To ensure the instrument works properly , safely and perform durably , it is necessary to read the operation manual carefully .

Our company are not only responsible for the repair , but also train distributors' ability of repairing . To repair the product smoothly in time , please contact your local distributor . Notice : With the development of technology and constantly updating of products , this manual will make the corresponding changes . Please forgive us not to notify the improvement of technical data and structure .

# Contents

|   |           |
|---|-----------|
| <b>1、 Safety Notes.....</b>                       | <b>1</b>  |
| 1.1 Overview.....                                 | 1         |
| 1.2 Safety Warning.....                           | 1         |
| 1.3 Safety Device.....                            | 2         |
| <b>2、 Performance &amp; Parameters.....</b>       | <b>4</b>  |
| 2.1 Overview of Instrument Component.....         | 4         |
| 2.2 Performance Index.....                        | 5         |
| 2.3 Technical Parameters.....                     | 5         |
| <b>3、 Preparation before operating.....</b>       | <b>7</b>  |
| 3.1 Requirement of Installation .....             | 7         |
| 3.2 Standard Delivery.....                        | 7         |
| 3.3 Installation .....                            | 8         |
| 3.4 Electrical Connection.....                    | 10        |
| <b>4、 Operation .....</b>                         | <b>11</b> |
| 4.1 Operate Panel Function &Control.....          | 11        |
| 4.2 Installation of Blade Holder.....             | 16        |
| 4.3Clamping The Specimen&Inserting The Blade..... | 18        |
| 4.4 Temperature Setting.....                      | 19        |
| 4.5 Time Setting.....                             | 20        |
| 4.6 Section Setting.....                          | 22        |
| 4.7 Retraction Setting.....                       | 24        |
| 4.8 Section Reference.....                        | 24        |
| <b>5、 Clearance &amp; Maintenance.....</b>        | <b>25</b> |
| 5.1 cleaning.....                                 | 25        |
| 5.2 Maintenance.....                              | 26        |
| <b>6、 Trouble Shooting.....</b>                   | <b>27</b> |

# 1、 Safety Notes

## 1.1 Overview

The Operator Manual contains important safety instructions and information . In order to operate the instrument safely , the operator must read carefully prior to starting up the instrument . It is very important to ensure safety and avoid instrument damage . Please keep the manual close to the instrument to read easily at any time .

This instrument was built and test in accordance with the safety regulation as specified below :

GB4793.1-2007 Medical Electrical Equipment First Part:Current Requirements for safety

▲ **Note:** The safety marks and protective device on both instrument and accessories may neither be removed nor modified , so as not to injure human body or instrument .

## 1.2 Safety Warning

Every principle person should read carefully and carry out strictly according to the following safety notes relating to transport , installation ,calibration , operation , maintenance , cleaning and all aspects of the instrument .

### 1.2.1 Warning during transport and installation

- The instrument may only be transported or moved in an upright position and the tilt angle should not exceed 45 ° .
- Prior to removing the microtome , remove the blade holder .
- The input voltage has been preset at the factory , please check this setting complies with your local power requirement before connecting to the main power
- Please use the power cord provided . If need to replace it , please use the power cord with earth wire .
- Do not operate this instrument in the room with the danger of explosion .
- Don't remove or modify the protective device on both instrument and accessories , in order to avoid injury to instrument or human body !

### 1.2.2 Warning of Operation

- Take care when handling microtome knives and disposable blades . The cutting edge is extremely sharp and might cause serious injury .
- Remove the knife/blade before detaching the blade holder from the instrument , and put the blade back into the blade box when not in use
- Never place the blade with the cutting edge facing upwards and never take out the blade with your hands.
- Please clamp the specimen block before clamping the blade .
- Prior to replacing the specimen and blade , please lock the handwheel and cover the blade guard on the cutting edge .
- Rotate the handwheel clockwise, otherwise it would affect section .
- Don't rotate the handwheel clockwise and counterclockwise frequently at top and bottom , it might lead to deviation of section thickness .

- Ensure no liquid enters into interior of instrument during working .

### 1.2.3 Warning during cleaning and Maintenance

- Only authorized person may do the service and repair .
- Before cleaning and maintenance of each part, please cut off the power , unplug the power plug , remove the blade holder and blade .
- Lock the handwheel before cleaning.
- Don't clean the instrument with corrosive liquid .
- Ensure no liquid enters into interior of instrument during clearing .
- After cleaning , don't turn on the instrument before it is completely dry .
- Turn the instrument off and unplug the power cord before changing the fuse . Please use the fuse according to the requirement and specification in operation manual .

## 1.3 Safety Device

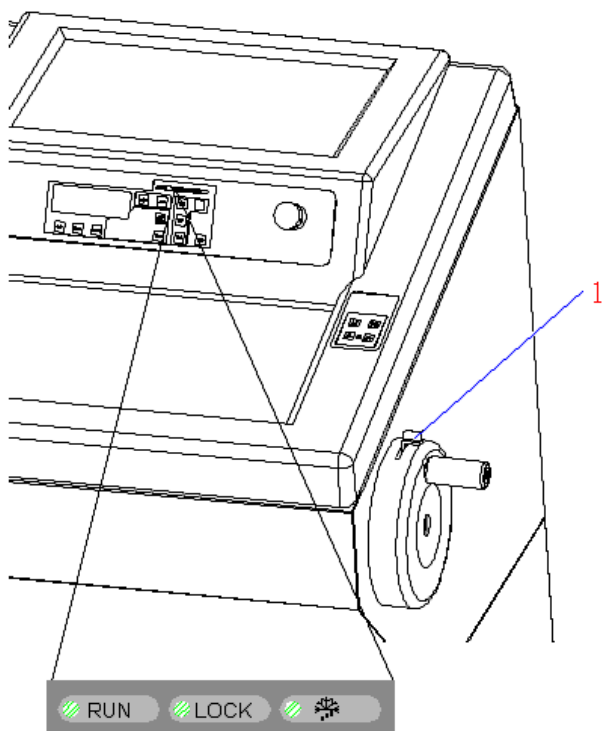

### Handwheel locking mechanism

As showed in Fig, it is the lock lever . Clockwise push the lever(1) until it lock the handwheel at the upright position . To unlock the handwheel , rotate counterclockwise the lever(1) .

As showed in Fig, the handwheel is locked .

If the lock activated , the "Lock" light will be lit on display panel , while the instrument can't run and the AUTO key is invalid .

- Don't lock the handwheel when the handwheel is rotating , otherwise it will damage the instrument .

▲ **Attention:** Before removing the instrument , changing specimen/blade or cleaning the instrument , the handwheel must be locked .

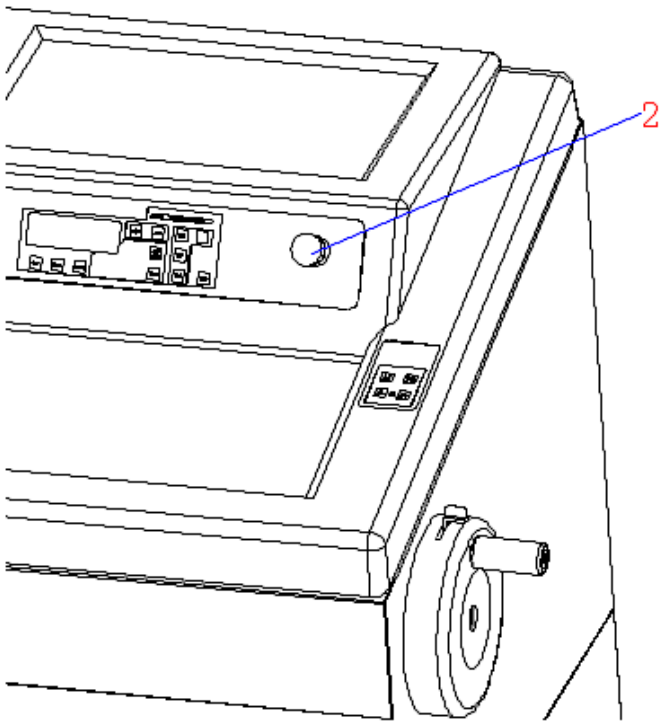

### Emergency Stop Function

Fig (2) is the switch for emergency stop .

The emergency-stop function is activated with the red switch (2) pressed while the main power off and all action stops .

To deactivate this function , turn the switch in the direction of the arrow .

Correct use in order :

Activate emergency switch -turn off power switch - deactivate - turn on power switch .

## 2、 Performance & Parameters

### 2.1 Overview- Instrument Components

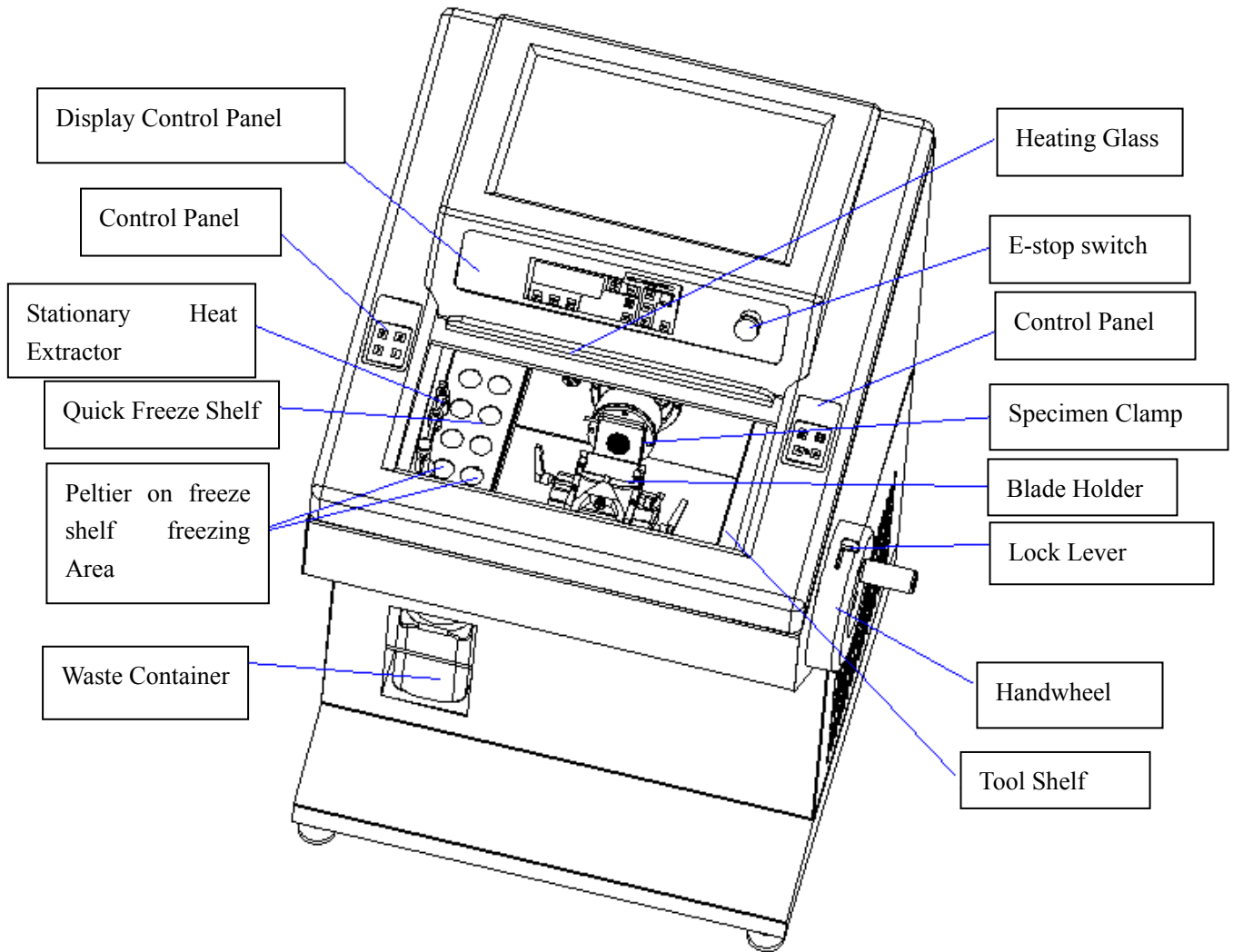





- ⊙ Electric coarse feed: Slow     $300\mu\text{m/s} \pm 30\mu\text{m/s}$   
   Rapid     $900\mu\text{m/s} \pm 30\mu\text{m/s}$
- ⊙ Section thickness range: 0 to  $100\mu\text{m}$   
   0 to  $3\mu\text{m}$ ,    in  $0.5\mu\text{m}$  increments  
   3 to  $10\mu\text{m}$ ,    in  $1\mu\text{m}$  increments  
   10 to  $20\mu\text{m}$ ,    in  $2\mu\text{m}$  increments  
   20 to  $100\mu\text{m}$ ,    in  $5\mu\text{m}$  increments
- ⊙ Trimming thickness range: 10 to  $600\mu\text{m}$   
   10 to  $50\mu\text{m}$ ,    in  $5\mu\text{m}$  increments  
   50 to  $100\mu\text{m}$ ,    in  $10\mu\text{m}$  increments  
   100 to  $600\mu\text{m}$ ,    in  $50\mu\text{m}$  increments
- ⊙ Retraction : 0~ $80\mu\text{m}$ , in  $5\mu\text{m}$  increments
- ⊙ Specimen feed:  $15\text{mm} \pm 0.2\text{mm}$
- ⊙ Vertical stroke:  $48\text{mm} \pm 1\text{mm}$
- ⊙ Specimen Max:  $35 \times 35\text{mm}$
- ⊙ Repositioning of blade holder base(left-right) :  $50 \pm 1\text{mm}$
- ⊙ Motorize cutting speed :  $75\text{-}230\text{mm/s} \pm 10\%$  .
- ⊙ Dimension:    Length:  $805\text{mm}$  ,  
   Width:  $715\text{mm}$  ,  
   Height:  **$1210\text{mm}$**  ,
- ⊙ Weight:    About  $130\text{kgs}$

### 3、 Preparation before operating

#### 3.1 Installation site requirement

- ⊙ The floor stand instrument fixed 4 wheels and 2 fixed support feet . The front only be used during movement . Remove the package and move the instrument to the installation site , then adjust the two fixed support feet and make the front wheels disabled .
- ⊙ Start the instrument after let it rest for at least 2 hours .
- ⊙ Ensure no other goods around the instrument . At least 300mm distance must be kept for ventilation and heat dissipation .
- ⊙ Ensure the working temperature and humidity must be in accord with the specification in manual .
- ⊙ Ensure leaving enough running space for rotating the handwheel .

▲ **Notice:** Do not operate the instrument in the room with explosion hazard .

#### 3.2 Standard Delivery

|                      |        |
|----------------------|--------|
| ⊙ Cryostat Microtome | 1 set  |
| ⊙ Blade Holder       | 1 set  |
| ⊙ Handwheel          | 1 pc   |
| ⊙ Specimen Clamp     | 10 pcs |
| ⊙ M5 Allen Key       | 1 pc   |
| ⊙ M3 Allen Key       | 1 pc   |
| ⊙ 7mm Wrench         | 1 pc   |
| ⊙ Disposable Blade   | 1 box  |
| ⊙ Power Cord         | 1 pc   |
| ⊙ Fuse               | 2 pcs  |
| ⊙ Brush              | 1 pc   |
| ⊙ Operate Manual     | 1 pc   |

● Please check the supply carefully with the packing list after opening the carton . If you have any doubt , contact the seller immediately .If you have any special requirement , please illuminate it before the order .

### 3.3 Installation

#### 3.3.1 Unpacking

As showed in the picture, the following is the instrument accessories:

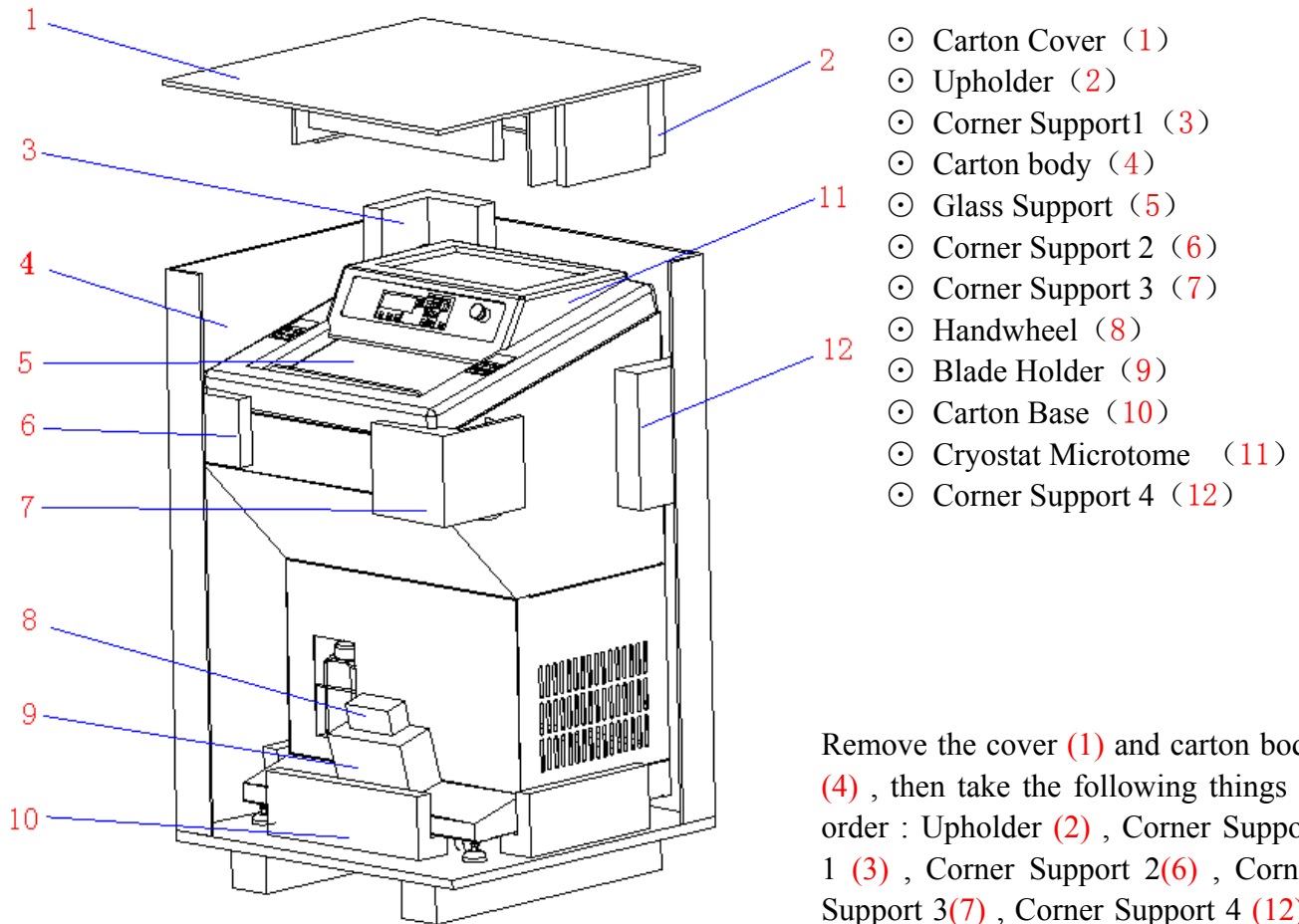

- ⊙ Carton Cover (1)
- ⊙ Upholder (2)
- ⊙ Corner Support1 (3)
- ⊙ Carton body (4)
- ⊙ Glass Support (5)
- ⊙ Corner Support 2 (6)
- ⊙ Corner Support 3 (7)
- ⊙ Handwheel (8)
- ⊙ Blade Holder (9)
- ⊙ Carton Base (10)
- ⊙ Cryostat Microtome (11)
- ⊙ Corner Support 4 (12)

Remove the cover (1) and carton body (4) , then take the following things in order : Upholder (2) , Corner Support 1 (3) , Corner Support 2(6) , Corner Support 3(7) , Corner Support 4 (12) , Handwheel (8) , Blade Holder (9) , Cryostat Microtome (11) , Glass Support (5) . Then take out other accessories in the inner box package to install the instrument.

### 3.3.2 Handwheel assembly

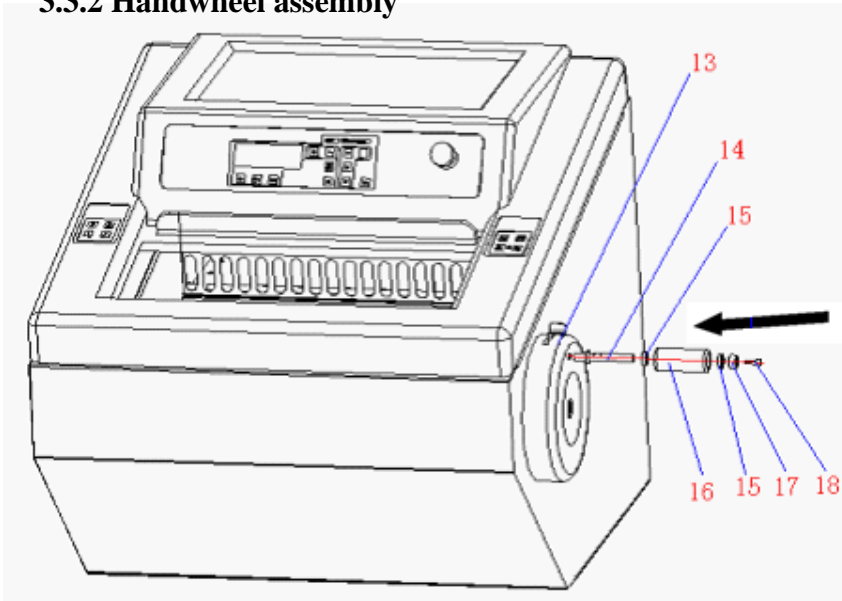

- Take out the handwheel accessories from handwheel box (8) .
- Tighten the handwheel lever (14) into handwheel (13) with 7mm wrench .
- Insert bearing(15) , handwheel cover (16) ,bearing (15) and handwheel washer (17) in order .
- Tighten them with M5 X 16 hexagon socket screw(18) .

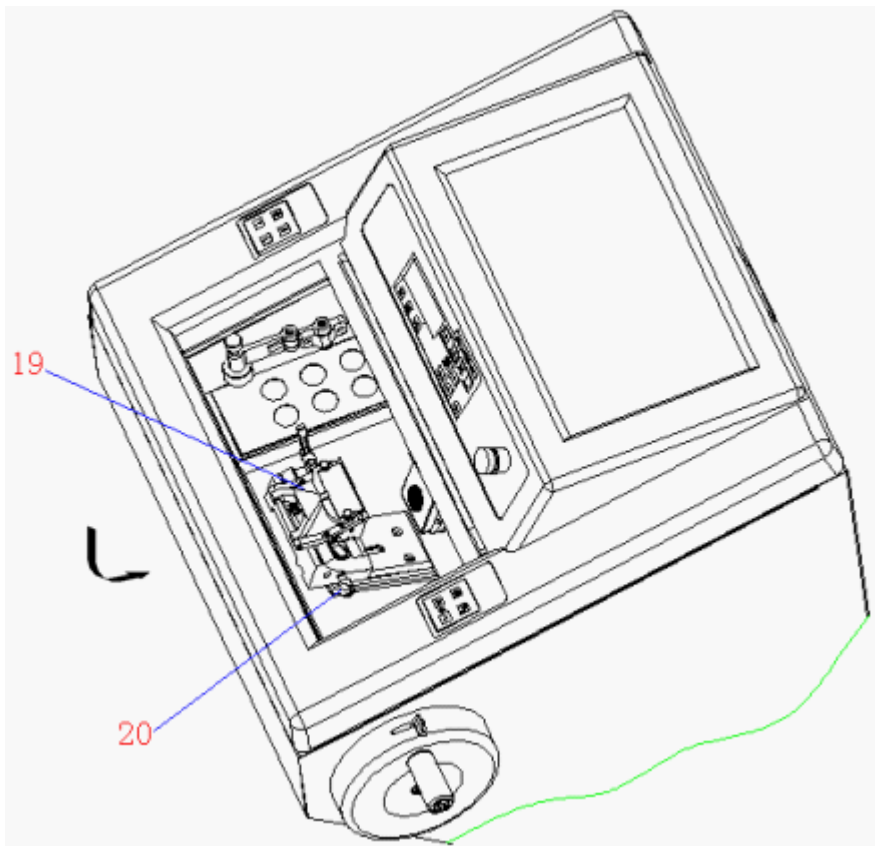

### 3.3.3 Blade holder

Take out the Blade holder (19) from the box, push it along the track as it is showed in the Fig , and then rotate the Blade holder lock lever(20) to lock the blade .

### 3.4 Electrical Connection

- The voltage has been preset at the factory . Before connecting the instrument to the power , please check that this setting complies with the local power requirements .
- Connect the instrument to a ground power socket to avoid accident .
- Please use the power cord provided . If need to replace it , please use the power cord with earth wire .

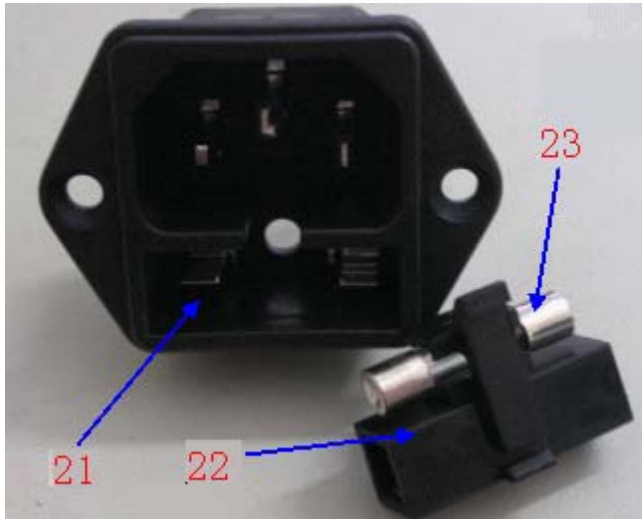

- Insert the fuse(23) into the fuse socket (22)as it showed in the Fig and insert the whole fuse socket into the socket(21) .

- Attention:Before changing the fuse , please cut off the power supply and pull the plug . Use the fuse according to the specification in operation manual .

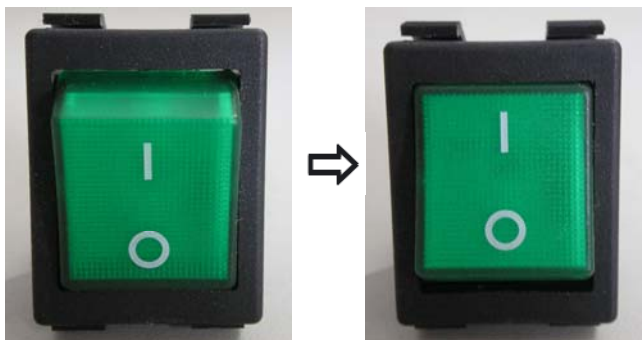

- As Fig shows power switch . Turn off as the left fig and turn on as right fig .

- After turning on the power , display panel light and the specimen block will be back to the original base position automatically with a beep .

## 4、 Operation

### 4.1 Control panel function & Control

All the parameters are set and displayed via control panel . After power on , use the control panel to operate the instrument as follows:

#### 4.1.1 Display Panel

|   |   |   |
|---|---|---|
| <p>Display area show main information such as : section thickness , trimming thickness, retraction , cryo chamber temperature , specimen clamp temperature and time .</p> | <p>The area is to set the value of section thickness , trimming thickness, retraction , temperature and time .<br/>⚙️ : Setting Key</p> | <p>Indicator light<br/>         RUN : Auto running indicator light<br/>         LOCK : Locking light for hand wheel.<br/>         ❄️ : Defrosting light</p> |
|---|---|---|

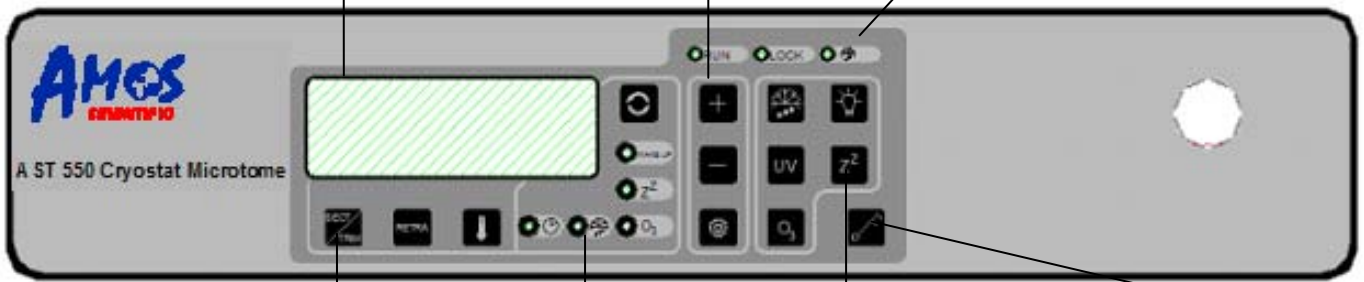

|   |   |   |                                 |
|---|---|---|---------------------------------|
| <p>SECT/TRIM: Alternative select key<br/>         RETRA: Retraction key<br/>         🌡️ : Cycle select key among specimen clamp temperature , cryo chamber temperature , freezing shelf temperature and ambient temperature</p> | <p>🕒 : Cycle key to select desired time mode<br/>         🕒 : Real time<br/>         ❄️ : Defrosting time<br/>         O<sub>3</sub>: Disinfection time<br/>         Z<sup>Z</sup>: Sleep time<br/>         WAKE UP: Wake up time</p> | <p>❄️ : Immediate defrosting key<br/>         UV: UV disinfection key<br/>         O<sub>3</sub>: Ozone disinfection key<br/>         💡 : Lamp key<br/>         Z<sup>Z</sup> : Immediate sleep key</p> | <p>🔑 : Key-board lock key .</p> |
|---|---|---|---------------------------------|



#### Three lines in blue-mask LCD .

The first line displays current status ( Key lock , defrosting, sleep and disinfection icons in order)

The second line displays section thickness, retraction, cryo chamber temperature and time etc .

The third line displays section/trimming situation, specimen clamp progress , slice quantity , temperature



situation and week time .

“ + ”、 “ - ” **The two keys are used for setting section/trimming thickness , time and temperature parameters.**

Section thickness value : 0 to 100μm

0 to 3μm, in 0.5μm increments

3 to 10μm, in 1μm increments

10 to 20μm, in 2μm increments

20 to 100μm, in 5μm increments

Trimming thickness value :10 to 600μm

10 to 50μm, in 5μm increments

50 to 100μm, in 10μm increments

100 to 600μm, in 50μm increments



**is setting key .**

This key is used to activate setting of the section/trimming thickness , retraction , temperature and time .

#### **Indicator light on Section mode**

**RUN:** When this light is lit up , it means this instrument is under auto running mode .

**LOCK :** if its led is lit up , it shows the handwheel is locked , and it is disabled at this moment to slice section.



, if its led lit up , it shows it is defrosting now .

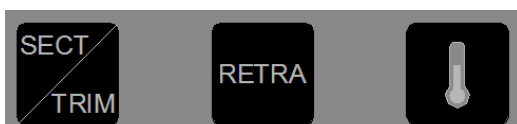

**SECT/TRIM is the alternating key between section mode and trimming mode .**

**RETRA is retraction key .**

This key is used to enter into retraction function .



**is temperature setting key .**

It is a cycle key to select desired item among specimen clamp temperature, cryo chamber temperature , freezing shelf temperature , and ambient temperature .



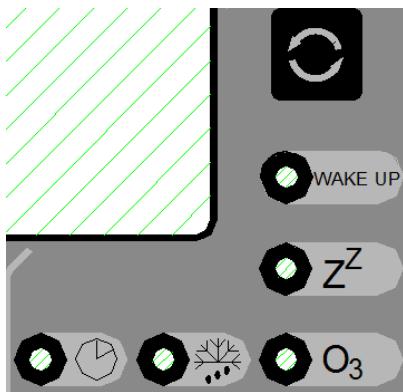

is a cycle key to select desired time mode .

Short push the button to select: real time , setting of real time , defrosting time , disinfection time , sleep time and wake up time .

is the real time indicator light .

The real time setting is ready when real time light is on

is defrosting time indicator light .

The defrosting time setting is ready when the defrosting time light is on.

**O<sub>3</sub>** is disinfection time indicator light .

The disinfection time setting is ready when the disinfection time light is on .

**Z<sup>Z</sup>** is the sleep time indicator light .

The sleep time setting is ready when the sleep time light is on.

**WAKE UP** is the wake up time indicator light .

The wake up time setting when the wake up time light is on .

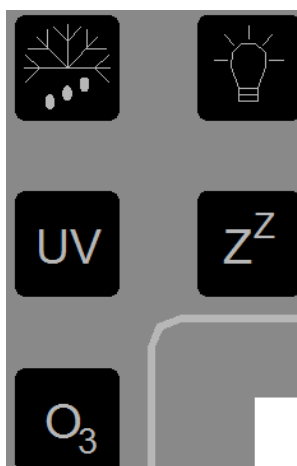

is the key to start defrosting immediately .

Hold on this button for about 5 seconds to start defrosting immediately , Meanwhile the defrosting indicator light is on. The process lasts about 30 minutes, and go back to work status automatically, light off .

**UV** is the button to turn on/off UV disinfection .

Short push this button to turn on UV disinfection , and turn it off by pushing it again .

**O<sub>3</sub>** is the button to turn on/off O<sub>3</sub> disinfection immediately

Short push this button to turn on O<sub>3</sub> disinfection and turn it off by pushing it again .



 is the button to turn on/off lamp .

Short push this button to turn on lamp and turn it off by pushing it again .

**Z<sup>Z</sup> is the button to turn on/off sleep function .**

 **Keyboard locking button**

This key is used to lock the keyboard

Hold on this button until the icon "  " is displayed on display panel ( As showed in left Fig ), the keyboard has been locked. All other keys are disabled at this moment , and release the lock by long press the button .

#### 4.1.2 Left control panel

The buttons is to control the specimen forward or backward moving , it has two speed.

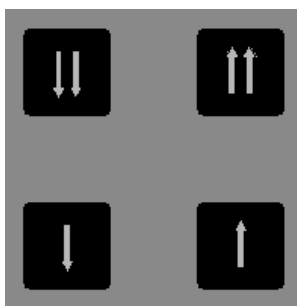
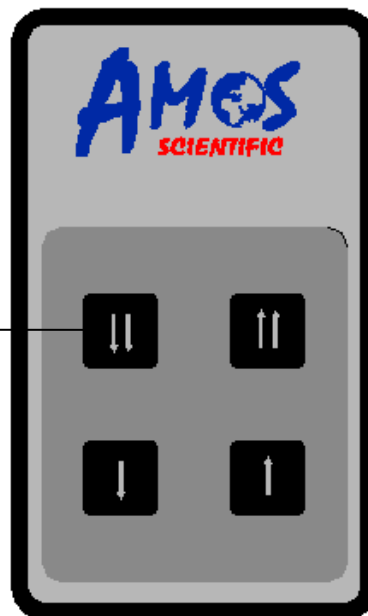

**Fast forward and fast backward key .**

Adjust the specimen position rapidly , the speed could reach  $900 \pm 30 \mu\text{m/s}$ .

**Slow forward and fast backward key .**

Adjust the specimen position slowly , the speed could reach  $300 \pm 30 \mu\text{m/s}$ .

● Specimen feed distance is 15mm . Once exceeding this distance , the buzzer will beep and the specimen movement stops .

### 4.1.3 Right control panel

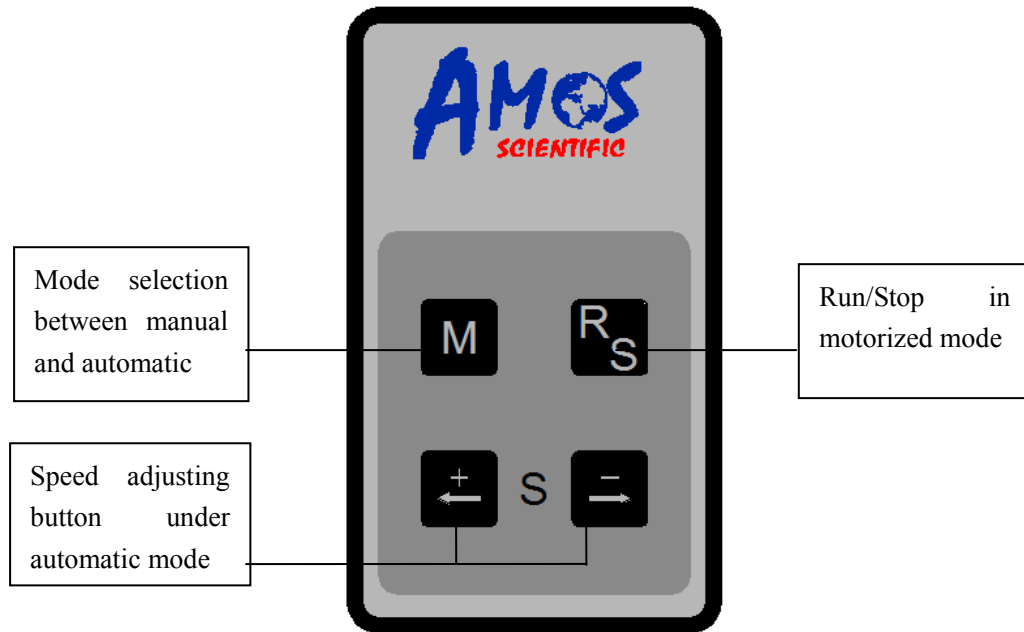

#### Mode selection between manual and automatic

Select the mode by pressing this button shortly.



#### Autorun/ Stop button in motorized mode

Press and hold this button about three seconds while the lights into autorun . When the motorized mode starts , the operation speed is slowest in default . Press the button to stop running while goes out .



#### Speed adjusting button

The button for adjusting speed of section can be activated only during running , and the speed range is 75-230mm/s±10% .

## 4.2 Installation of holder

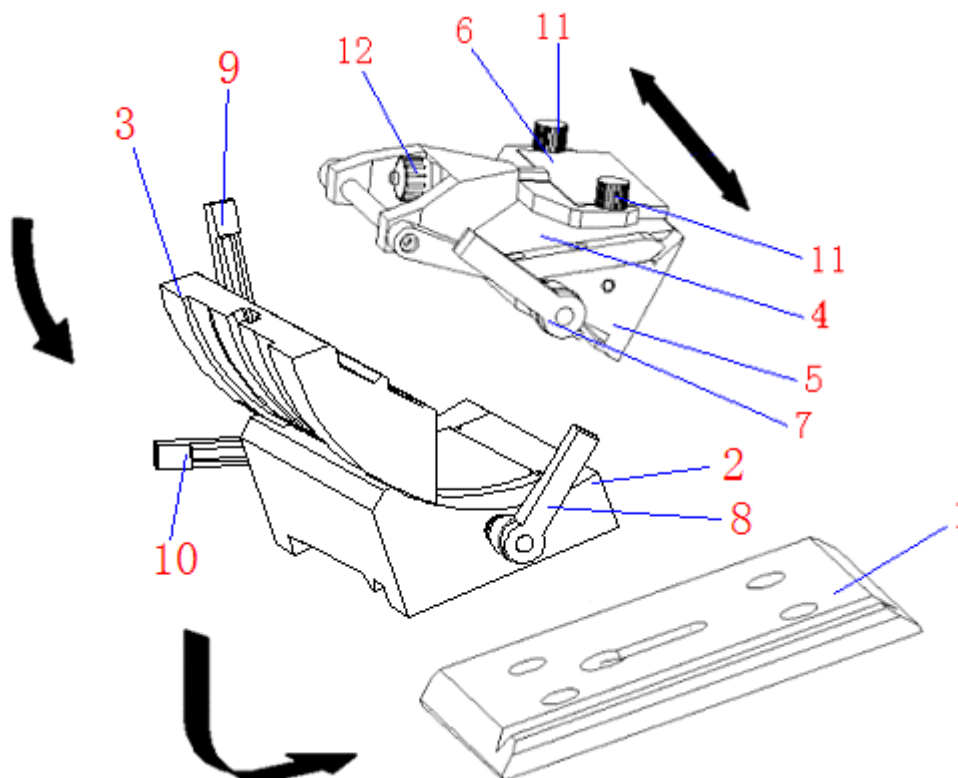

As fig shows , the blade holder is composed of the following parts : blade holder base (1) , longitudinal movable jaw (2) , rotating movable jaw (3) , movable knife clamp(4), fixed knife clamp (5), anti-roll plate (6) , fixed lever 1 (7) , fixed lever 2 (8) , fixed lever 3 (9) , fixed lever 4(10) , anti-roll plate lock knob (11) , anti-roll plate height adjusting knob(12) .

⊙ Insert the longitudinal movable jaw (2) into the track of blade holder base(1) , and rotate lever 2(8) to lock firmly . Then adjust the handle of lever 2(8) to horizon position .

⊙ Adjust the rotating movable jaw(3) into longitudinal movable jaw (2) , and rotate the lever 4(10) to lock firmly .

⊙ Put movable knife clamp (4) and fixed knife clamp(5) on rotating movable jaw (3) , rotate the lever 3 (9) to lock it firmly . Adjust the handle of lever 3 (9) to vertical position .

⊙ Rotate the lever 1 (7) to lock the movable knife clamp (4) and fixed knife clamp (5) .

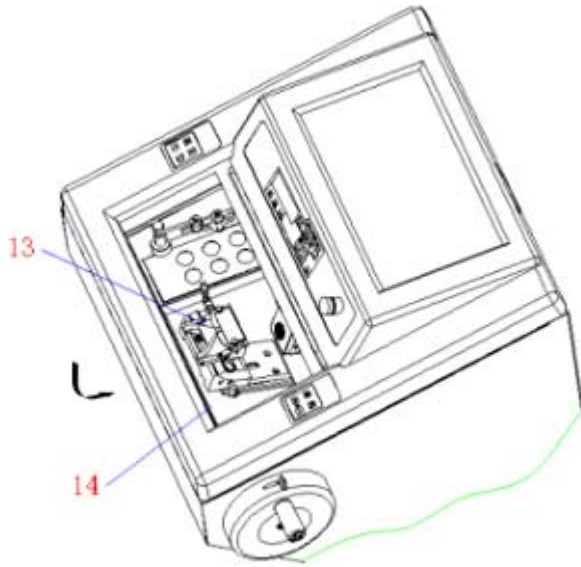

**Installation of blade holder and base**

As showed in picture , slide the blade holder(13) along the track(14) in cryostat microtome , rotate the handle of lever 2(8) to horizon position to lock the blade holder .

**▲Attention:** Before moving the instrument , take out the blade. And put the blade in box when not in use .

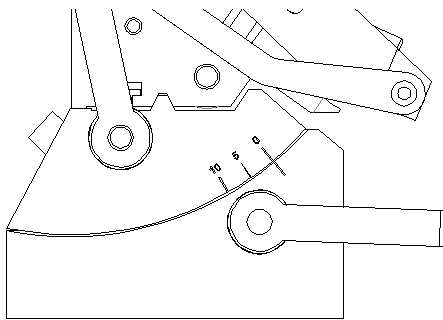

Tighten the blade and holder and the base holder with the four fixed poles and adjust the rotating angle as requirement before tightening it .  
The rotating angle is from 0 to 10 degree ( see the picture ) , the user can adjust the angle in this range according to the requirement .

**Anti roll plate adjustment**

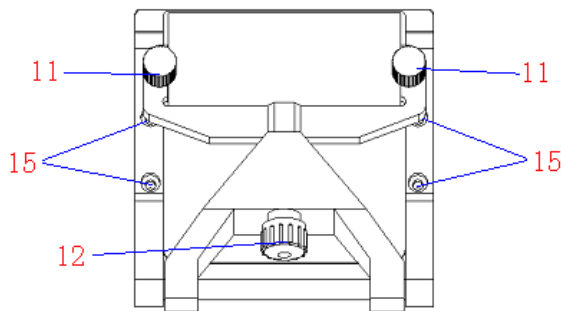

Anti roll plate is rectangular organic glass , do as follows :

- ⊙Insert the blade , and rotate the fixed pole(7) to vertical position for tightening it
- ⊙Lock the two anti roll plate knobs(11).
- ⊙Adjust the bolts (15) with 3 mm allen key to make blade parallel with anti roll plate , then tighten the bolts(15).

⊙Turn the knob(12) to adjust the height of anti roll plate.

**▲ Attention:** Take care to operate the blade holder and the blade , it is very sharp and easy to cause serious injury .

### 4.3 Clamping the specimen and Inserting the blade

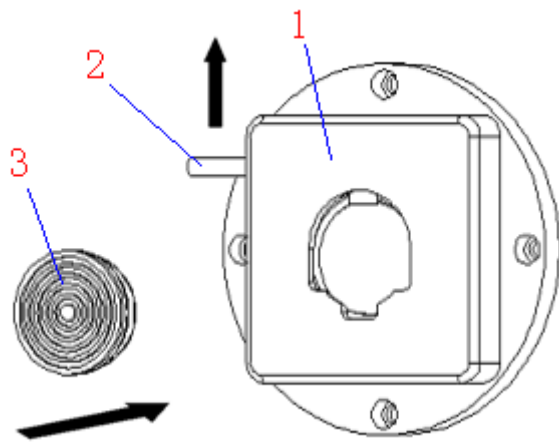

#### Clamping the specimen

As showed in the picture , rotate the clamp lever (2) , and insert the specimen(3) into clamp(1) , then loosen the clamp lever (2) .

● Always clamp the specimen before installing the blade to avoid injury .

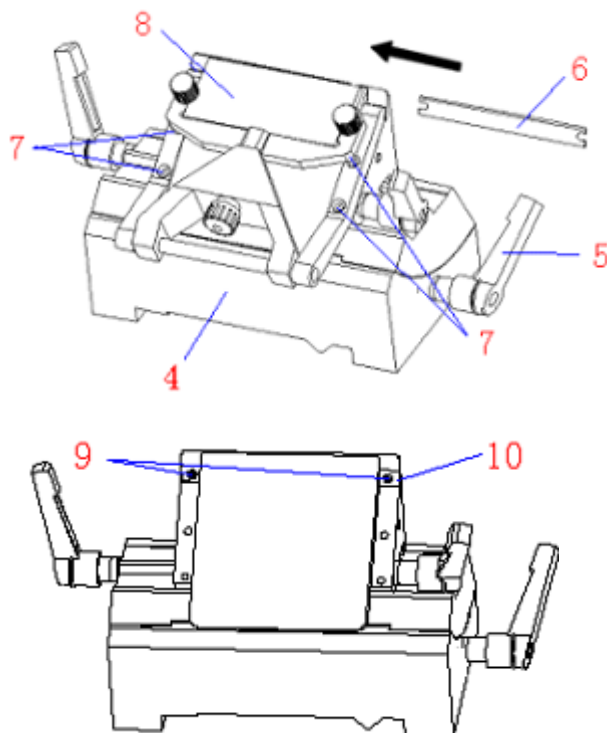

#### Blade inserting

As showed in the Fig , loosen the fixed lever (5) and push the blade(6) into blade holder(4) , then rotate the lever(5) to clamp the blade .

It uses blade in the picture , blade can be divided into two types : low & high profile .

If the high profile blade is needed , twist the four screws (7)out with 3mm Allen key , then take out anti roll plate module (8) , twist out the two screws (9) on base plate (10) to take out the base plate (10) . After inserting the blade , refix the anti-roll plate module(8) with the four bolts (7) .

● Take care when operating the blade holder and the blade . The cutting edge is extremely sharp and can cause serious injury .

## 4.4 Temperature setting

### 4.4.1 Specimen clamp temperature setting

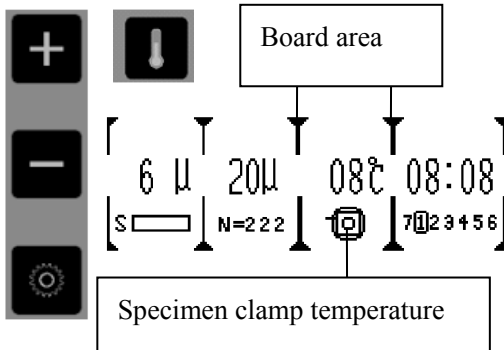

-Press shortly and the line of temperature board area gets thicker . When the display shows , it has entered into specimen clamp temperature display status .

-Then press to enter into temperature setting situation .

-The value can be adjusted by as showed in left Fig .

-After setting up, press again to exit or let it alone for 5 seconds which will exit automatically.

The temperature range is between -50 and 50° C .

### 4.4.2 Cryo chamber temperature setting

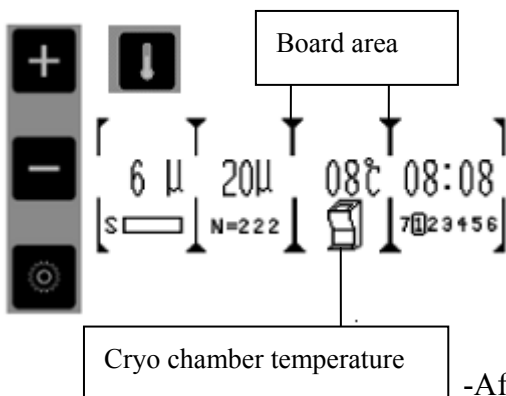

-Press shortly and the line of temperature board area gets thicker .

When the display shows , it has entered into cryo chamber temperature display status .

-Then press to enter into temperature setting situation . The value can be adjusted by as showed in left Fig .

-After setting up , press again to exit or leave it alone for 5 seconds to exit automatically.

The temperature range is between -50 and 50° C

### 4.4.3 Freezing shelf temperature

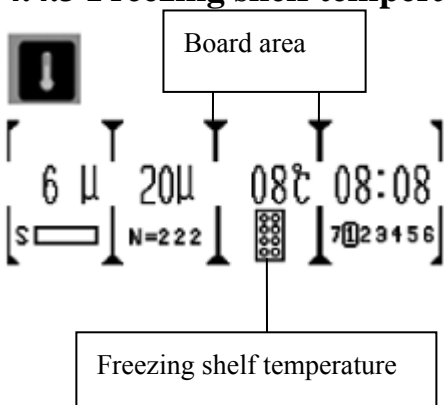

Press shortly and the line of temperature board area gets thicker . When the display shows , it has entered into freezing shelf temperature situation . The time on the display is actual temperature of freezing shelf .

#### 4.4.4 Ambient temperature

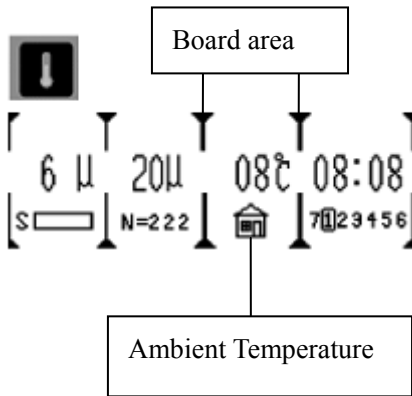

Press shortly and the line of temperature board area gets thicker .

When the display shows , it has entered into ambient temperature situation . The time on display is actual ambient temperature .

#### 4.4.5 Enabling specimen clamp peltier function



Hold on for a few seconds to turn on/off specimen clamp peltier function . When the function is activated , the above of temperature area will display icon “❄” as in left Fig, its working time is 15 minutes; the specimen clamp peltier function is able to be activated when the temperature of cryo chamber is below 8° C.

### 4.5 Time setting

#### 4.5.1 Real time setting

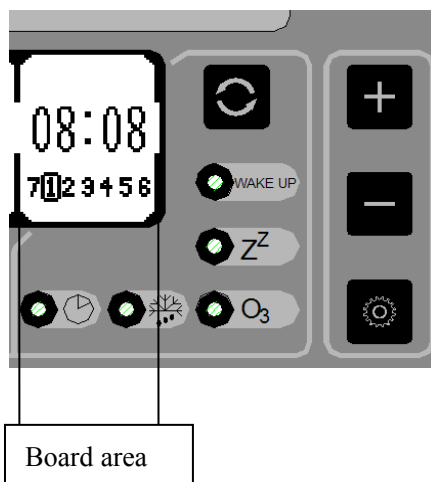

Press shortly and the line of time board area gets thicker .When the light is on which means the item real time has been selected (as in left Fig) , press to enter into real time setting . The value can be set through ; Press to set minute after hour setting , then press again to set week . After finishing the real time setting , press to enter into defrosting time setting or leave it alone for 5 seconds to exit automatically .



### 4.5.2 Defrosting time setting

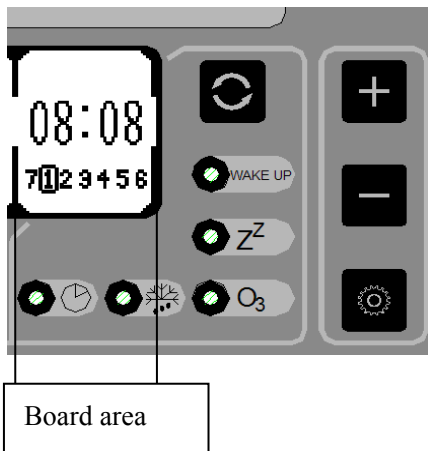

Press and the line of time board area gets thicker .When the light is on which means the item defrosting time has been selected (as in left Fig) , then press to enter into defrosting time setting . The value can be set through ; Press to set minute after hour setting , then press again to set week . After finishing the defrosting setting , press to enter into disinfection time setting or leave it alone for 5 seconds to exit automatically .

### 4.5.3 Disinfection time

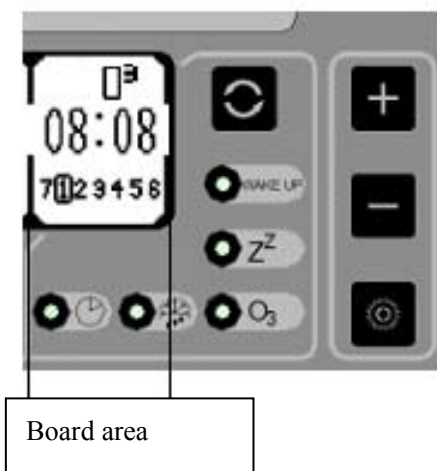

Press and the line of time board area gets thicker .When the light is on which means the item disinfection time has been selected (as in left Fig) , then press to enter into disinfection time setting . The value can be set through ; Press to set minute after hour setting , then press again to set week . After finishing the disinfection time setting , press to enter into sleep time setting or leave it alone for 5 seconds to exit automatically . When the disinfection is on , "O<sub>3</sub>" icon (shown at left) will be displayed above the time zone. And the disinfection function is activated, which means O<sub>3</sub> disinfection and UV disinfection are both activated together .

### 4.5.4 Sleep time setting

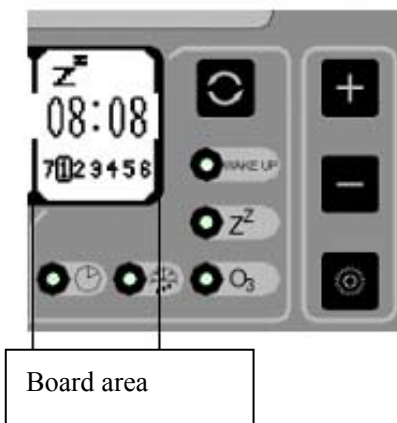

Press and the line of time board area gets thicker .When the light is on which means the item sleep time has been selected (as in left Fig) , press to enter into sleep time setting . The value can be set through ; Press to set minute after hour setting , then press again to set week . After finishing the sleep time setting , press to enter into wakeup time setting or leave

it alone for 5 seconds to exit automatically . When the sleep function is activated , "Z<sup>Z</sup>" icon (shown at left) will be displayed above the time zone. The sleep time can be set separately from Monday to Sunday .

### 4.5.5 Wake up time setting

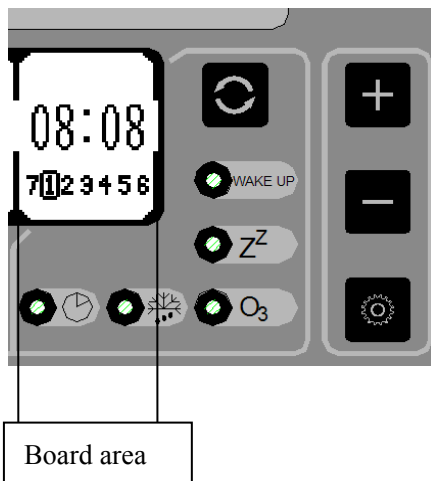

Press and the line of time board area gets thicker .

When the light is on which means the item wakeup time has been selected (as in left Fig) , press to enter into wakeup time setting . The value can be set through ;

Press to set minute after hour setting , then press again to set week . The wakeup time can be set separately from Monday to Sunday . If the user does not need to use this machine on a certain day , please set the hour value as 00 and the minute value as 60 ( 60 is ineffective time which can not wake up automatically) . After finishing the sleep time setting , press to exit or leave it alone for 5 seconds to exit automatically .

### 4.6 Section/Trimming setting



#### ⊙ Mode selection

Select the desired mode between manual and motorized mode . When select manual mode , the icon "" appears on the top of chamber temperature ( as left fig ) , and now pressing the run button have no response . When motorized mode is selected , only motorized section is allowed because if section by manual with force may cause instrument damage , can't work normally .

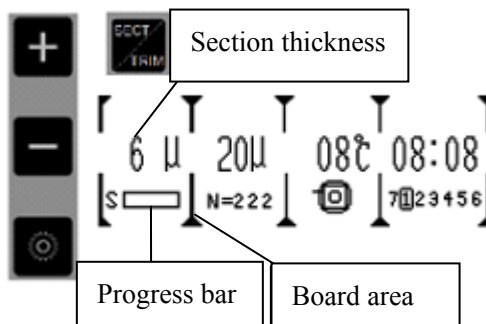

#### ⊙ Section setting

Press **SECT/TRIM** shortly and the line of section board area gets thicker . When the Letter before progress bar becomes "S" which means it has enter into section situation , press to enter into section setting . The section value can be set by . After finishing the setting , press again to exit or leave it alone for 5 seconds to exit automatically .

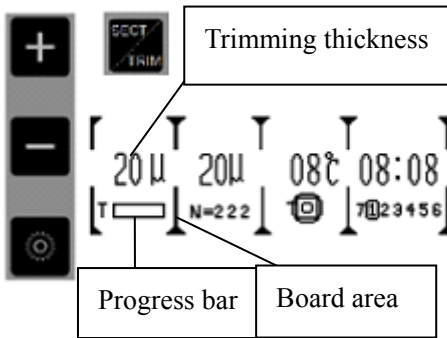

⊙ Trimming setting

Press **SECT/TRIM** shortly and the line of trimming board area gets thicker .When the Letter before progress bar becomes "T" which means it has enter into trimming situation , press to enter into trimming setting . The section value can be set by . After finishing the setting , press again to exit or leave it alone for 5 seconds to exit automatically .

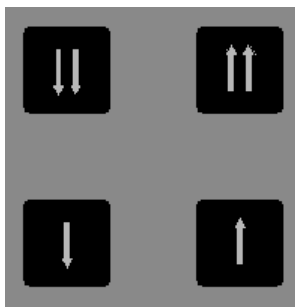

⊙ Feed

Press the key to adjust the specimen position to be parallel with the blade edge for section . When the blade is far away from specimen , press to move the specimen clamp forward or backward quickly; When the blade is close to the blade , press to adjust the position slowly .

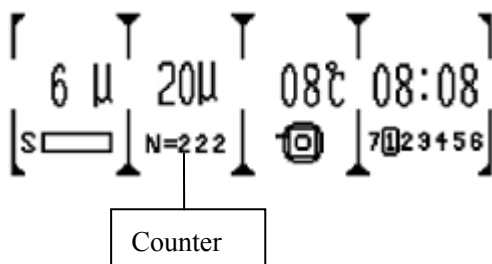

⊙ Section (in motorized mode)

Long press the button about three seconds while the LED illuminates and automatic to run . Short press the button to stop the running . The button for adjusting speed can only be active during running , the other buttons have no response .

Section ( in manual mode )



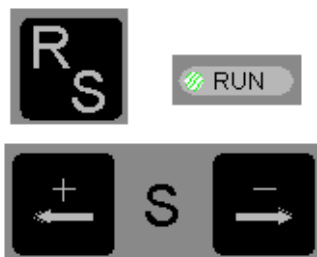

Just rotate the right handwheel to section/trim .

Counter function : On trimming situation, it shows 0 and starts to count when it turns to section situation .

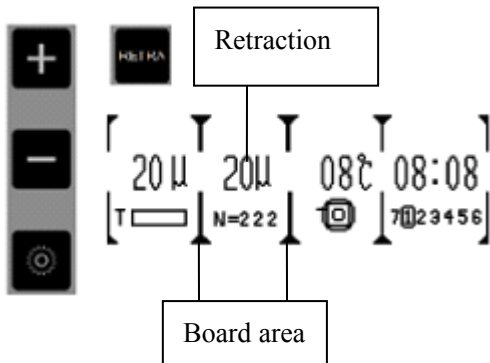

#### 4.7 Retraction setting



Press **RETRA** one time first and the line of retraction board area gets thicker, then press  to enter into retraction setting . The value can be set by   . After finishing the setting , press  again to exit or let it alone for 5 seconds to exit automatically .

#### 4.8 Section Reference

- 1、 When using cryostat microtome , please note that proper sectioning speed and correct anti-roll plate adjustment are important factors to obtain good quality section . The proper section speed is acquired through practical experience . The positions of anti roll plate adjustment is various , some of them are mutual influence , so they need to be adjusted carefully . The anti roll plate could not put on the cutting edge .
- 2、 When the tissue is freezing , the water in the tissue is frozen , the tissue get harder . The hardness changes with temperature , the lower the temperature is , the harder the tissue will be . It needs work through practice to identify appropriate temperature for better quality section . The sectioning temperature range of most fat-free without formalin fixed is best between -13℃ and -23℃ .
- 3、 To obtain high quality section , please pay attention to the following aspects :
  - (1) Proper cryo chamber temperature selection .
  - (2) Correct section operation .
  - (3) careful anti-roll plate adjustment .
  - (4) Sharp blade and appropriate sectioning angle
  - (5) The blade is clamped tightly .
  - (6) The specimen is clamped tightly .

Select a proper angle of the sectioning and specimen . The smaller the angle , the lower the section compressed . The harder the specimen, the larger the angle . If the section is still not good , please try to increase the angel from 0°.

Now there is no general rule to identify proper angle for different specimens , so try to find an appropriate angle of different specimens for good section .

- 4、 The frozen section is in contrary with paraffin section . It doesn't section long side of tissue but short

side in frozen section . Try to make contact line of tissue and blade shorter .

● After sectioning , place the specimen clamping system on the upper position and lock it . Detach the blade and put in in the box when it is not in use .

## 5、 Cleaning & Maintenance

### 5.1 Cleaning

⊙ Cleaning the instrument

Use the wet cloth to clean the areas always polluted during operation , for example the handle and the base holder locking lever and the storage area on the crust . Use the dry cloth to clean other appearance .

⊙ Cleaning the clamp

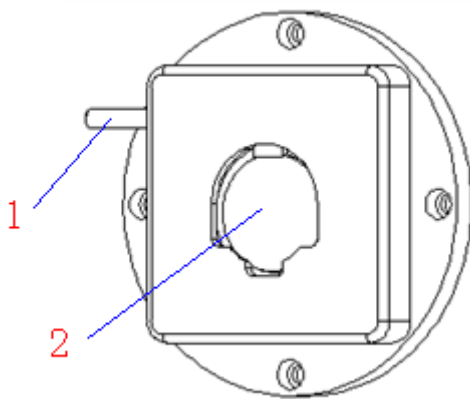

Specimen clamp

Position (1) which is often touched when operation , and position (2) which always contacts with the specimens . These two positions, especially position(2), are very easy to be polluted , so need to be cleaned frequently to ensure normal operation .

⊙ Cleaning the blade holder



Take down all the parts of blade holder as it is showed in the picture ad then clean all the parts separately , especially the following easily polluted parts : the sliding guide , fixed pole , blade clamp and the joint of the parts . And remember to clean the blade clamp every time before installing the blade to ensure good section .

To obtain a high quality section , it is important to keep cleaning the instrument . So the user must clean the instrument periodically or irregularly according to the total sectioning quantity to obtain the best section .

- Only authorized and qualified service personnel may access the internal components of the instrument for cleaning and maintenance .
- Before cleaning and maintenance turn off the instrument , pull out the plug and take down the blade holder and then clean all the parts of instrument separately . The blade must be taken down before cleaning the blade holder .
- Lock the handwheel before cleaning .
- Open the glass after turning off the instrument to keep the chamber dry !
- Do not use any corrosive solvent for cleaning !
- Ensure no liquid enters the interior of the instrument during cleaning !
- Keep cleaning the cryo chamber frequently !
- Do not turn on the instrument before it is completely dry .

## 5.2 Maintenance

### ⊙ Fuse replacement

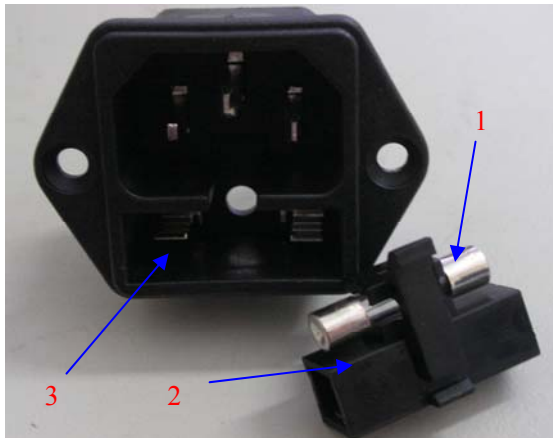

- Put the fuse (1) in the installation part (2) and then insert the installation part into the socket (3) .

- Cut off the power supply and pull out the plug before changing the fuse .

Attention : Before changing the fuse , please read the operation manual carefully . And make sure to use the specified fuse .

## 6、 Trouble Shooting

Below you find a list of the problems that most frequently occur. And they are mostly caused by the operator, so please read the operation manual carefully before using it .

| Problem  | Possible causes  | Corrective action   |
|--|--|---|
| <ul style="list-style-type: none"> <li>No display, no reaction to buttons pressed after the instrument is switched on</li> </ul> | <ul style="list-style-type: none"> <li>Mains cable not properly connected or it is break in the circuit</li> <li>Mains fuses defective</li> <li>The input voltage is not matched with the one showed in the marks</li> </ul> | <ul style="list-style-type: none"> <li>Reconnect the main cable or replace it .</li> <li>Replace the fuse .</li> <li>If it is not matched , please call for the professional personnel .</li> </ul>   |
| <ul style="list-style-type: none"> <li>The section is uneven from the second section</li> </ul>                                  | <ul style="list-style-type: none"> <li>The section angle of the blade is too small .</li> <li>The clamping setting is not steady</li> </ul>  | <ul style="list-style-type: none"> <li>Alternately thick and thin section are produced . In extreme case every second section is skipped , being followed by a very thickness . Systematically try wider clearance angle setting until optimum angel width has been found .</li> <li>Check if all the screw are tightened.</li> </ul> |
| <ul style="list-style-type: none"> <li>Section curl</li> </ul>   | <ul style="list-style-type: none"> <li>The space between anti roll plate and blade is too small or anti roll plate is lower than the blade</li> </ul>  | <ul style="list-style-type: none"> <li>Adjust the anti roll plate .</li> </ul>  |
| <ul style="list-style-type: none"> <li>Section soften</li> </ul>   | <ul style="list-style-type: none"> <li>The temperature of blade or anti roll plate is too high</li> </ul>  | <ul style="list-style-type: none"> <li>Extend the cooling time of blade or anti roll plate .</li> </ul>   |
| <ul style="list-style-type: none"> <li>The section sticks to the blade or anti roll plate</li> </ul>                             | <ul style="list-style-type: none"> <li>The blade or anti roll plate is polluted</li> </ul>   | <ul style="list-style-type: none"> <li>Clean the blade or anti roll plate</li> </ul>  |
| <ul style="list-style-type: none"> <li>Section splinter</li> </ul>   | <ul style="list-style-type: none"> <li>Temperature too low for tissue cut</li> </ul>   | <ul style="list-style-type: none"> <li>Reduce the cooling time and adjust cryo chamber temperature</li> </ul>   |

| Problem   | Possible causes  | Corrective action  |
|---|--|--|
| <ul style="list-style-type: none"> <li>• The surface of the section is in wave .</li> <li>• The section flies away and sticks to the microtome or other objects near the microtome</li> </ul> | <ul style="list-style-type: none"> <li>•The gradient of the blade is not proper .</li> <li>• It is effected by static .</li> </ul> | <ul style="list-style-type: none"> <li>• Readjust the gradient .</li> <li>• Increase the surrounding humidity o get rid of the static .</li> </ul> |
| <ul style="list-style-type: none"> <li>• The blade produces sounds when section , and the section are scratched and show vibrated mark</li> </ul>   | <ul style="list-style-type: none"> <li>•The gradient of the blade is not proper .</li> </ul>                                       | <ul style="list-style-type: none"> <li>• Reinstall the blade and adjust the gradient of the blade .</li> </ul>                                     |

**If there any other troubles can not be resolved , please contact with the manufacturer .**



## Standard accessories list

### AST550

| No | Accessory Name     | Qty    | Notes               |
|----|--------------------|--------|---------------------|
| 1  | Cryostat Microtome | 1 set  |                     |
| 2  | Blade Holder       | 1 set  |                     |
| 3  | Handling wheel     | 1 pc   |                     |
| 4  | Specimen clamp     | 10 pcs |                     |
| 5  | M5 Allen Wrench    | 1 pc   |                     |
| 6  | M3Allen Wrench     | 1 pc   |                     |
| 7  | 7mm Wrench         | 1 pc   |                     |
| 8  | Disposable blade   | 1 box  |                     |
| 9  | Power cord         | 1 pc   |                     |
| 10 | Brush              | 1 pc   |                     |
| 11 | Fuse               | 2 pcs  | 220V/8A<br>110V/15A |
| 12 | Operation Manual   | 1 pc   |                     |

Published by:



## **AMOS SCIENTIFIC PTY.LTD**

7 Gabrielle Court, Bayswater North VIC 3153 Melbourne , Australia

Tel: +61-410190188 Fax: +61-410190188

ABN 37 159 778 140

[www.amos-scientific.com](http://www.amos-scientific.com)