



TEC 2602 (Version: AMOSTEC2602OP20150317)

Slide Dryer

Operation Manual

AMOS SCIENTIFIC PTY.LTD. ABN37 159 778 140

www.amos-scientific.com

Fore Word

Thank you for purchasing our Slide Dryer. Presented in this 《 Operation Manual 》 are the functions and operation methods of the Slide Dryer and the matters needs attention for safety reasons. Please carefully read this manual before using so that you can understand its functions better and make full use of the products. If you have any questions, please contact us and we will provide best service for you at any time.

Please keep this 《Operation Manual》 appropriately for later consultation.

Contents

1. Safety Matters	1
1.1 Safety attentions.....	1
1.2 Conditions of installation.....	1
1.3 delivery inspection.....	1
2. Functions characteristics apply condition.....	2
3. Main structures Of Slide Dryer	2
4. Technical Data.....	3
5. Operation Manual	3
5.1Explanation Of Functional Keys.....	3
5.2Instructions.....	4
5.3Function Declaration Of Alarm.....	4
6.Layout Of Components & Wire Diagram Of Electric Equipment.....	5
7. Schematic Diagram.....	6.
8. Cleaning & Maintenance.....	7
9. Trouble shooting.....	7

1. Safety Matters

1.1 Safety attentions

- Please read these explicit rules. Act in violation of them can affect normal operation of the equipment, causing damages to the equipment or resulting in dangers.

 Use 220VAC \pm 10% at 50HZ or 110VAC \pm 10% at 60HZ



The input power supply must have good earth connection



The equipment should be installed far away from flammable and explosive objects



Don't open the equipment without authorization to prevent high voltage shock



Only professional maintenance worker are allowed to repair this product



Use fuses with correct capacity



Ensure that the power supply socket and circuit are able to withstand at least two times



The equipment should be installed far away from any interference source



Caution: Hot .

- **Electrical Protection Ratings: I class, B type**
- **Shell protection grade: IP53**
- **Baleful liquid Leak-in proof degree: Normal (enclosed equipment without liquid leak-in proof)**
- **Working system: Continuous running**

1.2 Conditions of installation

- (1) More than 20cm of space around the equipment for heat dissipation.
- (2) Free of water-drop ,steam, dust(including oily dust and flying dust)
- (3) Free of corrosive, flammable and explosive gas and liquid
- (4) Stable and avoid vibration
- (5) Free of electromagnetic interference
- (6) Ambient temperature and relative humidity at -10°C—+50°C and less than 90%,respectively

1.3 Delivery inspection

Although the product quality has already been inspected before leaving the factory, the following inspection is necessary at delivery because the products be damaged and accessories get missing during

transportation.

- (1) Open the packing boxes and check the contents to make sure that there is the product, operation manual, certificate, packing list and accessories.
- (2) Check the nameplate to make sure that the product is the one you ordered.
- (3) Make sure that the product and accessories do not get damaged or missing during transportation.

2. Functions characteristics apply condition

The Slide Dryer is made of sheet aluminum and has the advantages of artistic appearance, non touchable temperature control, stable performance, program control system and easy and reliable operation. It is mainly used for flattening and drying of the microtome sections of tissues.

3. Main structures of Slide Dryer



4. Technical Data

- Table top: 324mm×272mm
- Temperature range: ambient temperature ~90°C
- Temperature control accuracy: ±1°C
- Rated voltage: 220V±10% at 50Hz or 110V±10% at 60Hz
- Fuse : 220V/3A or 110V/5A
- Rated power: 350W
- Outside dimensions (mm): 324(W) ×300(D) ×85(H)
- Weight:2.75kg

5. Operation Manual

● 5.1 Explanation of Functional keys

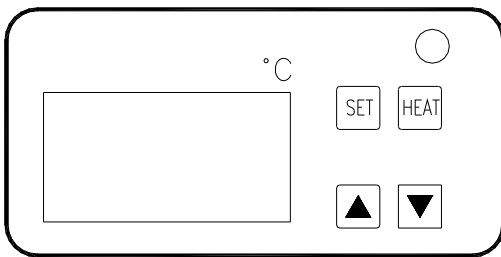

SET---Used for setting temperature. Press this button, the indicator lamp will be light up, and the setting temperature value display on the LED. Adjust the temperature by **▲** and **▼** , and press **SET** to exit the setting status. Or the system will test and exit the setting status automatically if **SET** not pressed to exit.

HEAT----Press this key to select HEAT ON or HEAT OFF, the machine is on the heating mode if the red indicator lamp lights up. And machine is heating off if the lamp lights off.

The buzzer sounds is single that indicate the operation is effective.

▲ ----Press the key to increase the temperature degree short press the button as 1 degree to plus, long press the button to plus as 0.1 at beginning to 1 after a period time and then keep quickly as 1 plus.

▼ ----- Press the key to decrease the temperature degree ,press the button quickly as 1 degree to decrease, long press the button to decrease as 0.1 at beginning to 1 after a

period time and then keep quickly as 1 decrease.

● 5.2 Instructions

- 1) Before operation, check whether every part of the machine is in normal condition.
- 2) Connect the machine to power on and turn on the power switch at the back cover. Right now the buzzer sounds and the LED display the ambient temperature, which means the machine is in normal working state.
- 3) Now you can operate the machine according to the explanation of key instructions mentioned above.

4) Temperature error and regulation

The unit with high precision of temperature control already been adjust at factory before shipping, if customer feel the temperature control accuracy can't meet demand, please calibration as the method:

For example: If the setting temperature is 48°C, After the unit is heating up thirty minutes about later, test the water temperature is $T_{water}=49.3^{\circ}C$ by thermometer.

Calculation of the value necessary to compensate $T_c=T_{setting}-T_{water}$ ($-1.3^{\circ}C$)

Press **SET** enter into the setting status, the green indicator lamp will light up, long press **HEAT** 4 seconds more, LED display the current temperature compensation ($-4^{\circ}C \sim +6^{\circ}C$). If the temperature compensation displayed $2^{\circ}C$ which request to plus the $T_c(-1.3^{\circ}C)$ to get the new compensate T_c' ($2^{\circ}C-1.3^{\circ}C=0.7^{\circ}C$), press **▲** Or **▼** to adjust, and exit after five seconds automatically.

● 5.3 Function Declaration Of Alarm

If the buzzer is sounds continuously, that means the machine malfunctioned :

E01 After power on and heating, the temperature don't changes, the possible reasons is the digital sensor measurement failure or heating film, solid state relay is damaged or disconnected.

E02 the digital sensor measures the temperature is over 100 degree, the solid state relay or sensor meet problem.

E03 the digital sensor measures the temperature is under -10 degree, please preclude the ambient temperature reason firstly. If the ambient temperature within the requirement, the possible reason is the digital sensor is damaged, no signal input, please replace the new sensor.

6.Layout Of Components & Wire Diagram Of Electric Equipment

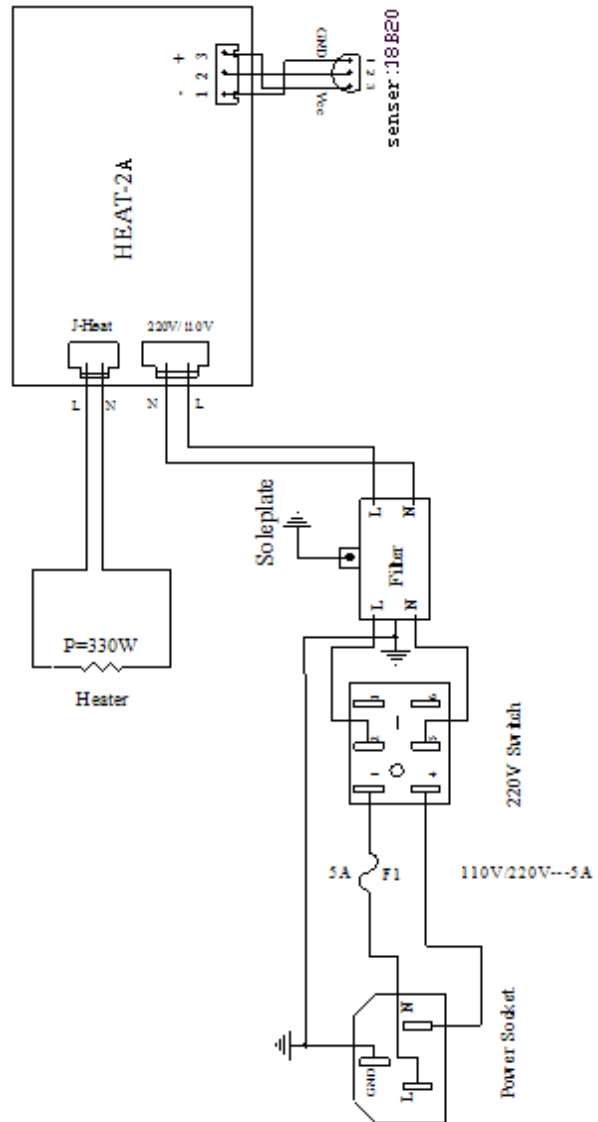
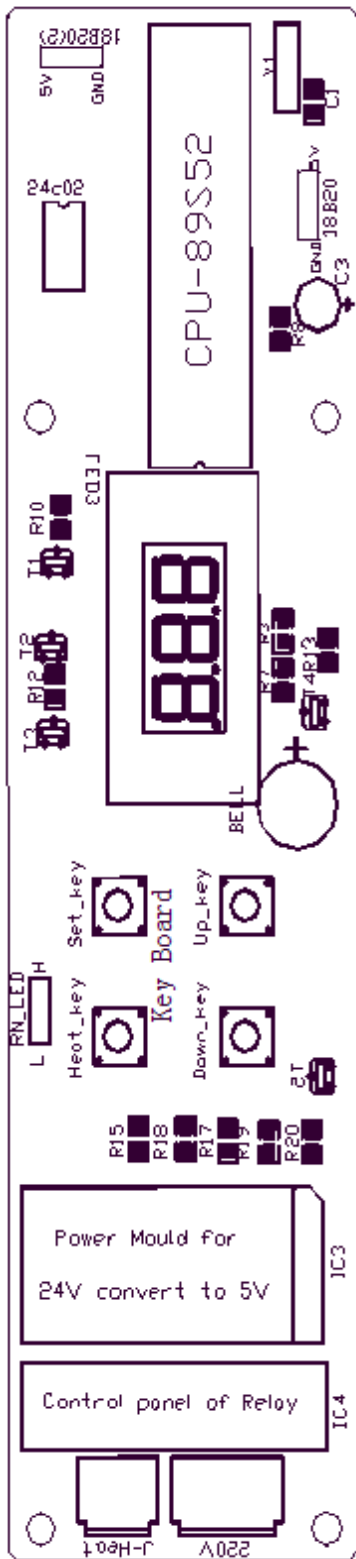

7. Schematic Diagram

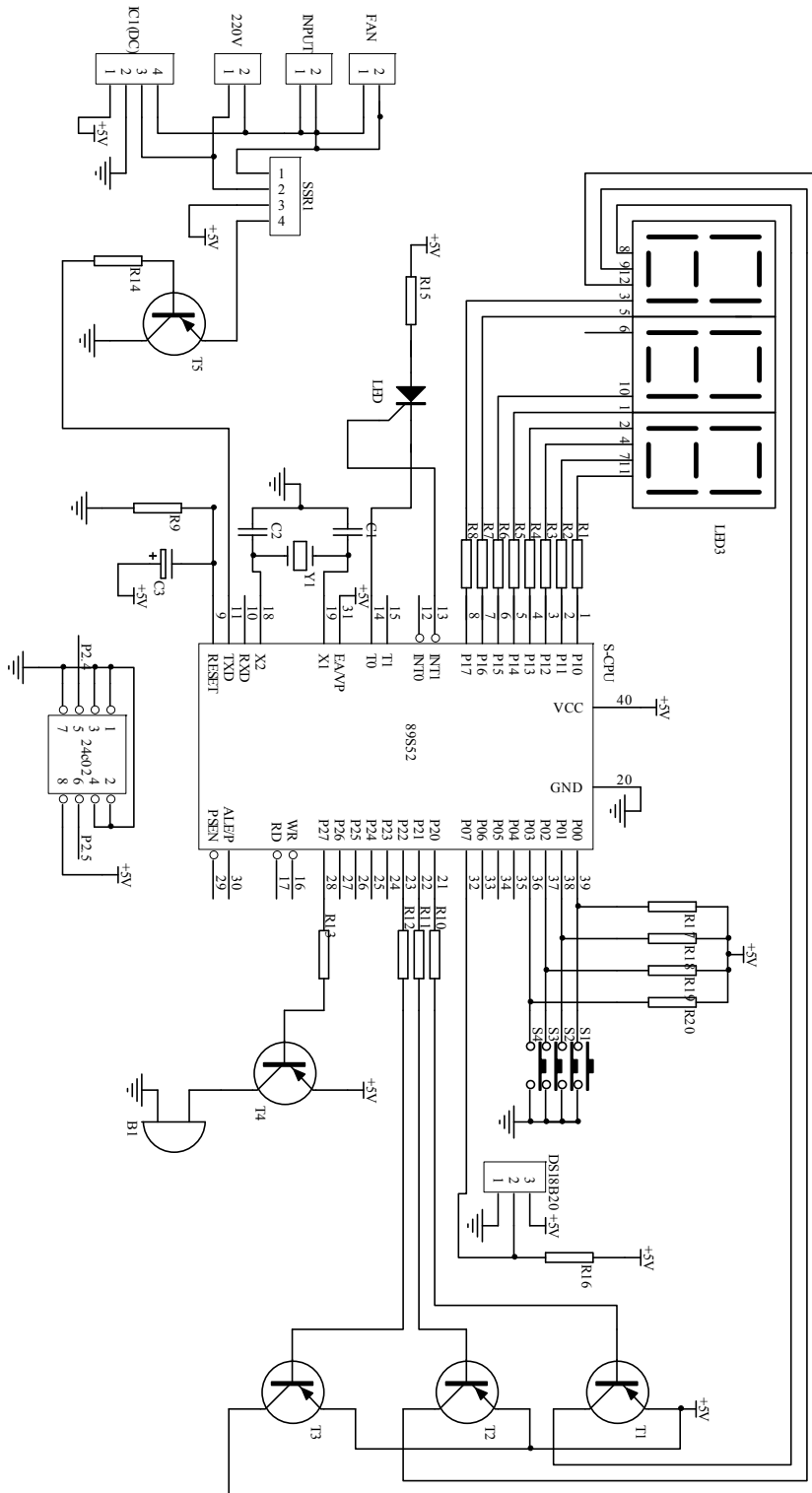

8. Cleaning & Maintenance

- Prior to operation, please earnestly read this Operation Manual and carry out by this Manual.
- Keep the instrument cleaning. Please clean up the remaining substance and dirt after work finished.
- Forbid using sharp hard object to harm the worktable.
- Install fuse as figure(1) shown then put it into the installation part as figure(2) shown. At last put the whole installation into the receptacula as figure(3) shown.
- Before replacing the fuse must turn off the power switch and disconnect the power. Specification of fuse: 3A (220V) ,5A(110V).

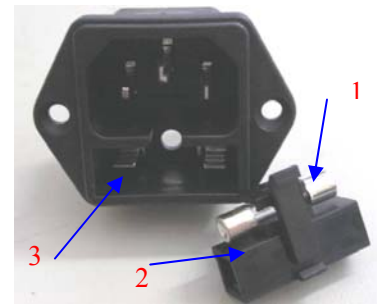

9. Trouble shooting

Symptom	Cause	Judgment	Remedy
No display	Poor connection of power supply	Connection again	Connection well
	Switch at the rear of the equipment not on	Turn on	Turn on
	Fuse blow	Take out the fuse to check its internal resistance by multimeter, if the value is infinite, the fuse is broken	Replace a new one
Buzzer sounds	Temperature sensor was damaged	Connect a new sensor to terminal to start machine, if all be okay, it means the sensor is broken	Replace a new one

Standard Accessories List

No	Accessory Name	Qty	Notes
1	Slide Dryer	1 unit	
2	Power Cord	1pc	
3	Fuse	2pcs	
4	Operation Manual	1pc	

Published by:



AMOS SCIENTIFIC PTY.LTD

7 Gabrielle Court, Bayswater North VIC 3153 Melbourne , Australia

Tel: +61-410190188 Fax: +61-410190188

ABN 37 159 778 140

www.amos-scientific.com